

Model 916 LED Street Light & Parking Luminaire

Model 916 LED Street Light is designed to provide efficient and uniform illumination of roadway and parking surfaces. The durable construction and design of the Model 916 luminaire provides over 50,000 hours of service.

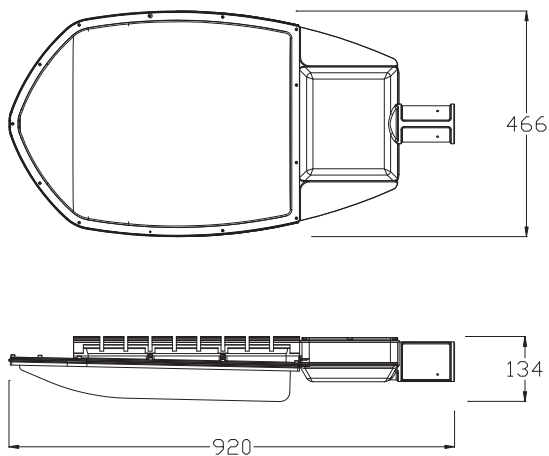
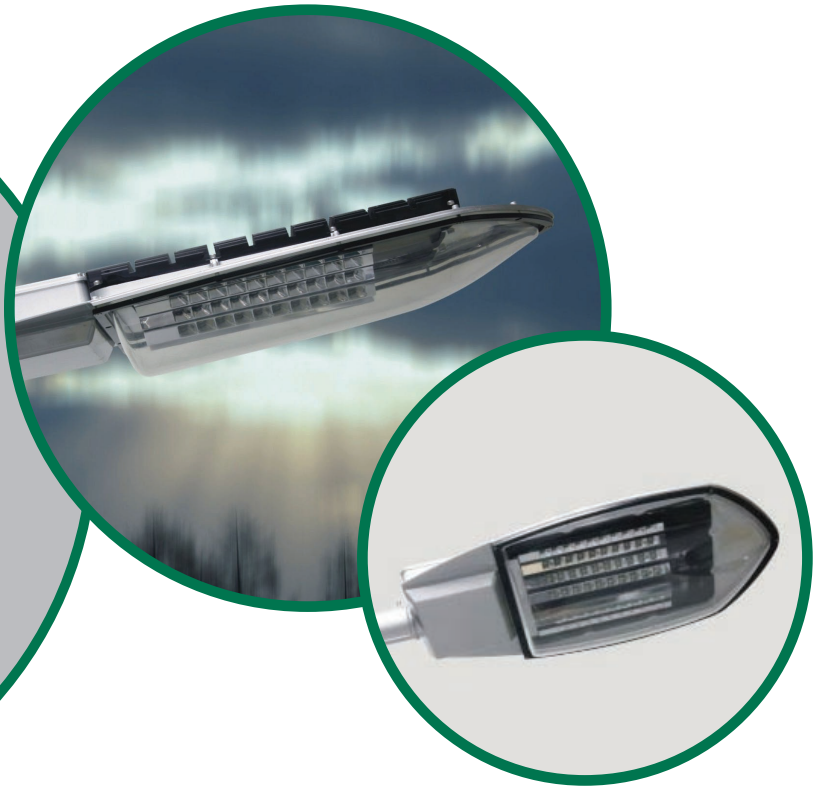

SPECIFICATIONS				
Model	916-80	916-96	916-120	916-140
# of LEDs:	80	96	120	140
Lamp Flux:	6,650	7,700	9,800	11,550
Input Power:	95W	110W	140W	165W
LED Efficacy:	100 lm/W			90 lm/W
CCT:	Available in 4600k to 5600k			
Input Voltage:	100VAC - 240VAC			
Power Factor:	> 0.90			
CRI:	> 70			
IP Rating:	IP65			
Working Temp.:	-40° to +50° C			
Materials:	Aluminum Housing/Polycarbonate Lens			
Weight:	26.5 lbs.			
Warranty:	5 year limited warranty			

xternaLED
by Hilux

3900 Central Parkway | Hudsonville, MI 49426

616.896.1192 | sales@xternaled.com

www.xternaled.com